

BION

C1306

Pepe Fornas
Design 2022



EN	MATERIALS		Steel
	FINISHES	Steel	Shade
		Matt black	Matt black
		Aged gold	Matt white
	SPECIFICATIONS (UE)	6xG9 LED 5W 2700lm 2700K (Included) Dimmable 220-240 V, 50/60 Hz	
	ENERGY LABEL	E	
	ADJUSTABLE HEIGHT	The height is configured during the installation of the pendant, threading the different tubes (3x30 cm + 3x50 cm)	
ES	MATERIALES		Metal
	ACABADOS	Metal	Tulipa
		Negro mate	Negro mate
		Oro envejecido	Blanco mate
	ESPECIFICACIONES (UE)	6xG9 LED 5W 2700lm 2700K (Incluida) Regulable 220-240 V, 50/60 Hz	
	CLASIFICACIÓN ENERGÉTICA	E	
	ALTURA REGULABLE	La altura se configura durante la instalación del colgante, roscando los diferentes tubos (3x30 cm + 3x50 cm)	

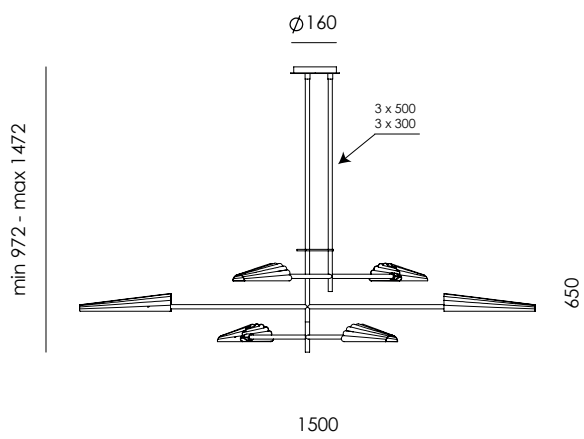

ICONS

